

CMOS 8-Bit Microcontroller

TMP86FP24F

The TMP86FP24 is a flash type MCU which includes 48 K bytes flash memory. It is a pin compatible with a mask ROM product of the TMP86CP24. Writing the program to built-in flash memory, the TMP86FP24 operates as the same way as the TMP86CP24. The TMP86FP24 has a 2 K bytes BOOT ROM (masked ROM) for programming to flash memory.

Product No.	Flash Memory	BOOT ROM	RAM	Package
TMP86FP24F	48 K × 8 bits	2 K × 8 bits	2 K × 8 bits	P-LQFP80-1212-0.50A

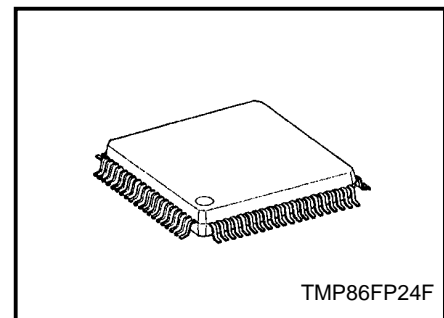

030619EBP1

- The information contained herein is subject to change without notice.
- The information contained herein is presented only as a guide for the applications of our products. No responsibility is assumed by TOSHIBA for any infringements of patents or other rights of the third parties which may result from its use. No license is granted by implication or otherwise under any patent or patent rights of TOSHIBA or others.
- TOSHIBA is continually working to improve the quality and reliability of its products. Nevertheless, semiconductor devices in general can malfunction or fail due to their inherent electrical sensitivity and vulnerability to physical stress. It is the responsibility of the buyer, when utilizing TOSHIBA products, to comply with the standards of safety in making a safe design for the entire system, and to avoid situations in which a malfunction or failure of such TOSHIBA products could cause loss of human life, bodily injury or damage to property.
In developing your designs, please ensure that TOSHIBA products are used within specified operating ranges as set forth in the most recent TOSHIBA products specifications. Also, please keep in mind the precautions and conditions set forth in the "Handling Guide for Semiconductor Devices," or "TOSHIBA Semiconductor Reliability Handbook" etc..
- The TOSHIBA products listed in this document are intended for usage in general electronics applications (computer, personal equipment, office equipment, measuring equipment, industrial robotics, domestic appliances, etc.). These TOSHIBA products are neither intended nor warranted for usage in equipment that requires extraordinarily high quality and/or reliability or a malfunction or failure of which may cause loss of human life or bodily injury ("Unintended Usage"). Unintended Usage include atomic energy control instruments, airplane or spaceship instruments, transportation instruments, traffic signal instruments, combustion control instruments, medical instruments, all types of safety devices, etc.. Unintended Usage of TOSHIBA products listed in this document shall be made at the customer's own risk.
- The products described in this document are subject to the foreign exchange and foreign trade laws.
- TOSHIBA products should not be embedded to the downstream products which are prohibited to be produced and sold, under any law and regulations.
- For a discussion of how the reliability of microcontrollers can be predicted, please refer to Section 1.3 of the chapter entitled Quality and Reliability Assurance/Handling Precautions.



Purchase of TOSHIBA I²C components conveys a license under the Philips I²C Patent Rights to use these components in an I²C system, provided that the system conforms to the I²C Standard Specification as defined by Philips.

Pin Assignments (Top view)

P-LQFP80-1212-0.50A

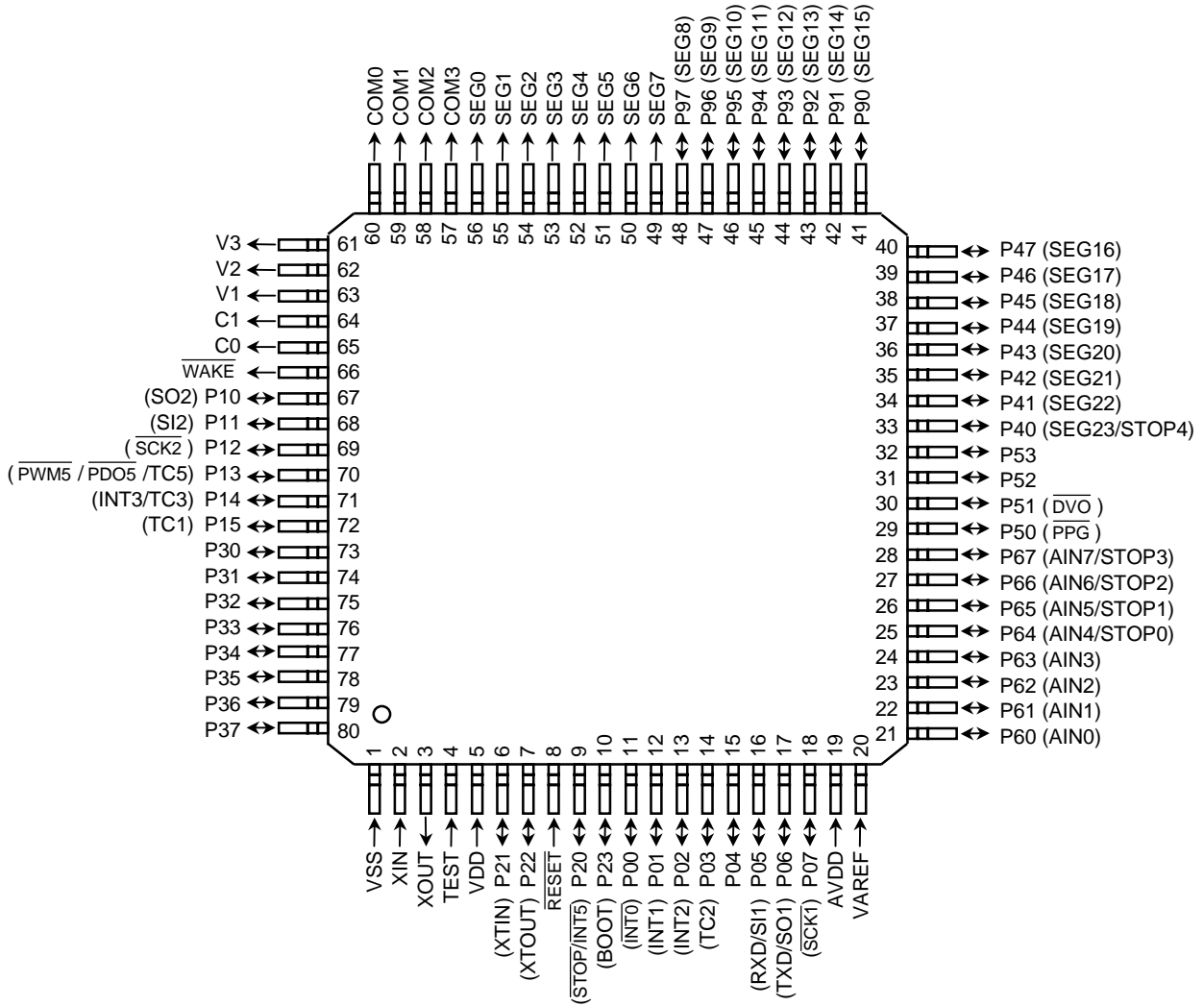

Note: The mask ROM product (TMP86CP24) doesn't have a BOOT function in P23 pin.

Block Diagram

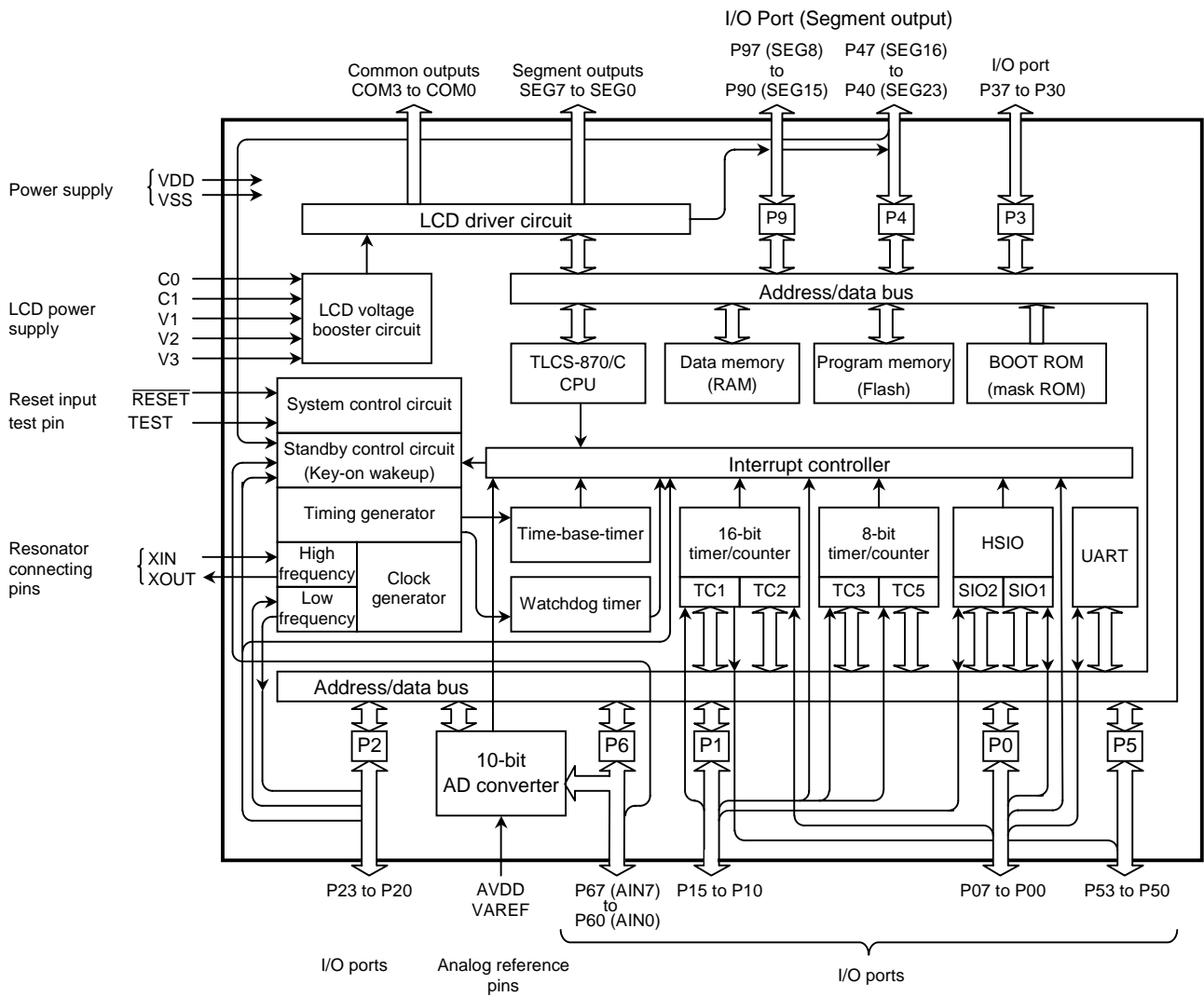

Pin Funtions

The TMP86FP24 has MCU mode and serial PROM mode.

(1) MCU mode

In the MCU mode, the TMP86FP24 is a pin compatible with the TMP86CP24 (Make sure to fix the TEST pin to low level).

(2) Serial PROM mode

In the serial PROM mode, programming to flash memory is available by executing BOOT ROM. For details, refer to 2.1 "Serial PROM Mode".